

## Swinging wall console Type SKW with counter plate Type SKWG

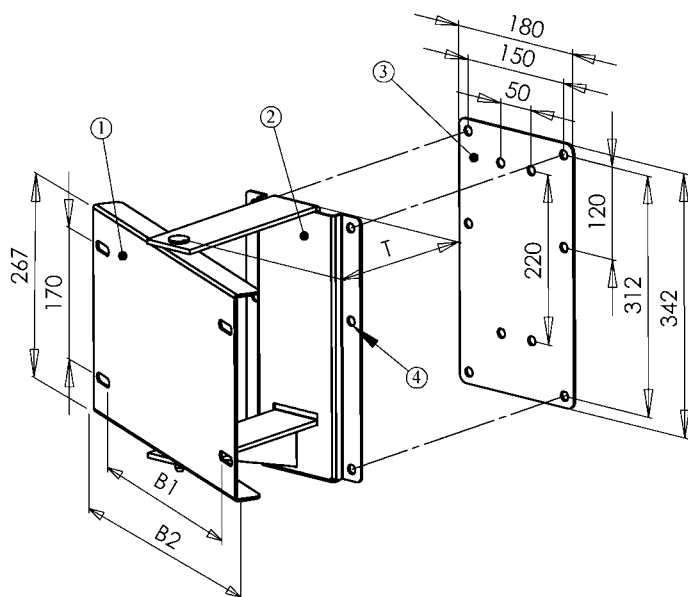

Counter plates will be used for light weight walls, e. g. panel walls.

The fix part of SKW14/20 consists of the U-part only without counter plate.

The counter plate fits all Types of SKW.

Pos.	Text
1	Lose part
2	Fixed part
3	Counter plate type SKWG
4	All holes $\varnothing$ 12

Type	Suitable for hose reels Type	B1	B2	T	weight SKW [ kg ]	weight counter plate [ kg ]
SKW 14/20	ST14; ST20	157	210	120	3,4	1,45
SKW40/1	ST40/10/2; ST40/12/1 ST40/12/2; ST40/19/1	263	316	188	6,6	1,45
SKW40/2	ST40/19/2; ST60/10/3	365	420	235	7,6	1,45

## Angled console for fastening to walls

**Type KHDp**, mounting of the hose reel parallel to the wall.

**Type KHDr**, mounting of the hose reel right angled to the wall.

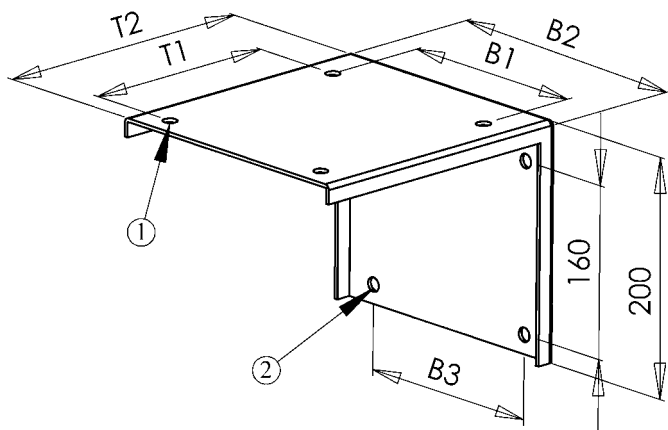

Pos.	Text
1	4 holes $\varnothing$ 11
2	4 holes $\varnothing$ 11

## Console for fastening to wall and ceiling Type KWH and counter plate Type KWHG

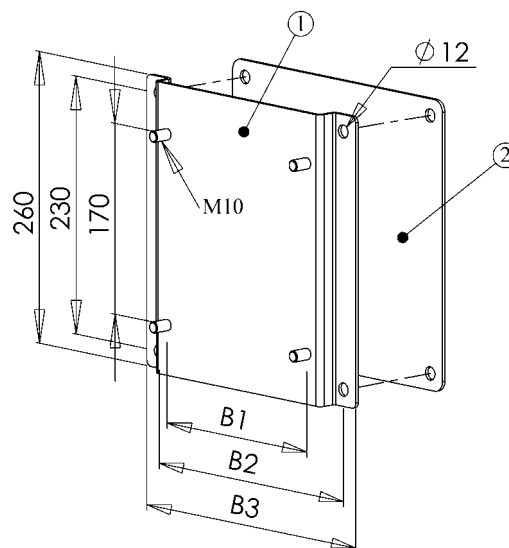

Pos.	Text
1	Type KWH
2	Counter plate KWHG

Type	suitable for	B1	B2	B3	T1	T2	*kg
KHDp14/20	ST14; ST20	170	210	161	165	222	2,4
KHDp40/1	ST40/10/2; ST40/12/1; ST40/12/2; ST40/19/1	170	210	161	282	328	2,9
KHDp40/2	ST40/19/2; ST60/10/3	170	210	161	382	428	3,4
KHDr14/20	ST14; ST20	176	222	176	170	390	3,4
KHDr40/1	ST40/10/2; ST40/12/1; ST40/12/2; ST40/19/1	282	328	282	170	390	4,9
KHDr40/2	ST40/19/2; ST60/10/3	382	428	382	170	390	6,3

Type	suitable for	B1	B2	B3	*kg
KWH14/20	ST14; ST20	176	232	263	1,8
KWH40/1	ST40/10/2; ST40/12/1; ST40/12/2; ST40/19/1	282	338	369	2,5
KWH40/2	ST40/19/2; ST60/10/3	382	438	469	3,1

Counter plates will be used for light weight walls, e.g. panel walls.

\* Weight of the consoles without counter plate.