

**Technical data single combustion chamber type BR1000Ö + BR1000G, 110/230V**

**\*Weights without safety and control device**

	Heating coils		BR1000o	BR1000G
	Operating pressure			
Pressure/Volume, Heating coil	3/8"	300 bar	4,17 Ltr.	4,17 Ltr.
		500 bar	3,66 Ltr.	3,66 Ltr.
	1/2"	200 bar	7,60 Ltr.	7,60 Ltr.
Allowed operating pressure [bar]	3/8"		300	300
			500	500
	1/2"		200	200
Max. allowed operating temperature [°C] (°F)			95 (203)	95 (203)
Min. allowed operating temperature [°C] (°F)			60 (140)	60 (140)
Max. volume flow [ l/min ]			20	20
Min. volume flow [ l/min ]			13	10
Dimensions width x depth x height [mm]			700 x 660 x 1050	700 x 660 x 1050
Weight [kg]	3/8"	300 bar	*68,0	77,0
		500 bar	*78,0	87,0
	1/2"	200 bar	*60,0	69,0
Tube length of the heating coil [ m ]	3/8"		40	40
	1/2"		32	32
Ø Diameter of the heating coil [mm]	3/8"	300 bar	17,2	17,2
		500 bar	18,0	18,0
	1/2"	200 bar	21,4	21,4
Operating voltage/ frequency <u>current drain</u>			110/230V AC 2 A	110/230V AC 2,5 A
			12V DC 25A	
Current consumption				
Nozzle [ G/h]			1,75	
Oil flow [kg/h]			5,61 - 7,42	
Fuel			Heating oil EL	Natural gases L + H Fluid gases: propane, butane
Gas consumption max natural gas L [m <sup>3</sup> /h] natural gas H Propane / Butane				7,0 – 10
				5,8 – 7,0
				2,0 – 2,7
Gas – joint pressure				20 – 100 mbar
Effective range of capacity [kW]			65 - 80	45 - 68
Degree of efficiency of combustion [%]			>= 91	> = 91
Max. exhaust gas temperature [°C] (°F)			200 (392)	180 (356)
Flue gas loss [%]			<= 9	<= 9
Soot value according to Bacharach			0 - 1	0

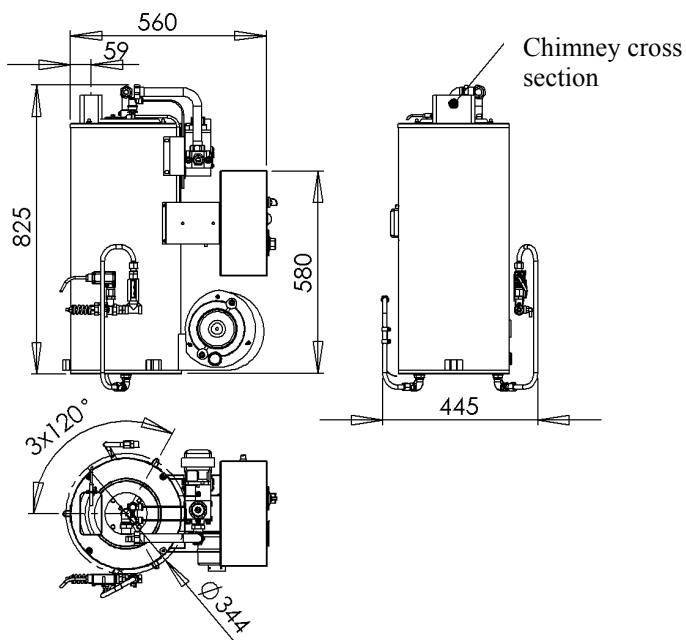

**If the number of combustion chambers is increased this multiplies the following items of the several modular variations: Contents of the heating coil, volume, flow, weight, current consumption, fuel consumption, heating capacity.**